

## COL-SFP-FE-EX

155Mbps SFP Optical Transceiver, 1310nm 40km Reach

### Features

- ◆ Up to 155Mbps data-rate
- ◆ 1310nm FP laser and PIN photodetector for 40km transmission
- ◆ Compliant with SFP MSA and SFF-8472 with duplex LC receptacle
- ◆ Digital Diagnostic Monitoring:  
Internal Calibration or External Calibration
- ◆ Compatible with RoHS
- ◆ +3.3V single power supply
- ◆ Operating case temperature:  
Standard : 0 to +70°C  
Industrial : -40 to +85°C

### Applications

- ◆ SDH STM-1, S-1.1,L-1.1, L-1.2
- ◆ SONET OC-3 IR1,LR1,LR2
- ◆ Other optical links

### Description

The SFP transceivers are high performance, cost effective modules supporting 155Mbps data-rate and 40km transmission distance with SMF.

The transceiver consists of three sections: a FP laser transmitter, a PIN photodiode integrated with a trans-impedance preamplifier (TIA) and MCU control unit. All modules satisfy class I laser safety requirements.

The transceivers are compatible with SFP Multi-Source Agreement (MSA) and SFF-8472. For further information, please refer to SFP MSA.

## Absolute Maximum Ratings

**Table 1 - Absolute Maximum Ratings**

Parameter	Symbol	Min	Max	Unit
Supply Voltage	Vcc	-0.5	4.5	V
Storage Temperature	Ts	-40	+85	°C
Operating Humidity	-	5	85	%

## Recommended Operating Conditions

**Table 2 - Recommended Operating Conditions**

Parameter	Symbol	Min	Typical	Max	Unit
Operating Case Temperature	Standard	0		+70	°C
	Industrial	-40		+85	°C
Power Supply Voltage	Vcc	3.13	3.3	3.47	V
Power Supply Current	Icc			300	mA
Data Rate			155		Mbps

## Optical and Electrical Characteristics

**Table 3 - Optical and Electrical Characteristics**

Parameter	Symbol	Min	Typical	Max	Unit	Notes
<b>Transmitter</b>						
Centre Wavelength	$\lambda_c$	1260	1310	1360	nm	
Spectral Width (RMS)	$\sigma$			4	nm	
Average Output Power	Pout	-5		0	dBm	1
Extinction Ratio	ER	9			dB	
Optical Rise/Fall Time	$t_r/t_f$			1.3	ns	
Data Input Swing Differential	V <sub>IN</sub>	300		1860	mV	2
Input Differential Impedance	Z <sub>IN</sub>	90	100	110	$\Omega$	
TX Disable	Disable		2.0	Vcc	V	
	Enable		0	0.8	V	
TX Fault	Fault		2.0	Vcc	V	
	Normal		0	0.8	V	

Receiver						
Centre Wavelength	$\lambda_c$	1260		1580	nm	
Receiver Sensitivity				-34	dBm	3
Receiver Overload		-3			dBm	3
LOS De-Assert	LOS <sub>D</sub>			-36	dBm	
LOS Assert	LOS <sub>A</sub>	-45			dBm	
LOS Hysteresis		1		4	dB	
Data Output Swing Differential	V <sub>out</sub>	400		1800	mV	4
LOS	High	2.0		V <sub>cc</sub>	V	
	Low			0.8	V	

**Notes:**

1. The optical power is launched into SMF.
2. PECL input, internally AC-coupled and terminated.
3. Measured with a PRBS 2<sup>23</sup>-1 test pattern @155Mbps, BER  $\leq 1 \times 10^{-10}$ .
4. Internally AC-coupled.

## Timing and Electrical

**Table 4 - Timing and Electrical**

Parameter	Symbol	Min	Typical	Max	Unit
Tx Disable Negate Time	t <sub>on</sub>			1	ms
Tx Disable Assert Time	t <sub>off</sub>			10	$\mu$ s
Time To Initialize, including Reset of Tx Fault	t <sub>init</sub>			300	ms
Tx Fault Assert Time	t <sub>fault</sub>			100	$\mu$ s
Tx Disable To Reset	t <sub>reset</sub>	10			$\mu$ s
LOS Assert Time	t <sub>loss_on</sub>			100	$\mu$ s
LOS De-assert Time	t <sub>loss_off</sub>			100	$\mu$ s
Serial ID Clock Rate	f <sub>serial_clock</sub>			400	KHz
MOD_DEF (0:2)-High	V <sub>H</sub>	2		V <sub>cc</sub>	V
MOD_DEF (0:2)-Low	V <sub>L</sub>			0.8	V

**Diagnostics**

**Table 5 – Diagnostics Specification**

Parameter	Range	Unit	Accuracy	Calibration
Temperature	0 to +70	°C	±3°C	Internal / External
	-40 to +85			
Voltage	3.0 to 3.6	V	±3%	Internal / External
Bias Current	0 to 100	mA	±10%	Internal / External
TX Power	-5 to 0	dBm	±3dB	Internal / External
RX Power	-28 to -3	dBm	±3dB	Internal / External

**Digital Diagnostic Memory Map**

The transceivers provide serial ID memory contents and diagnostic information about the present operating conditions by the 2-wire serial interface (SCL, SDA).

The diagnostic information with internal calibration or external calibration all are implemented, including received power monitoring, transmitted power monitoring, bias current monitoring, supply voltage monitoring and temperature monitoring.

The digital diagnostic memory map specific data field defines as following.

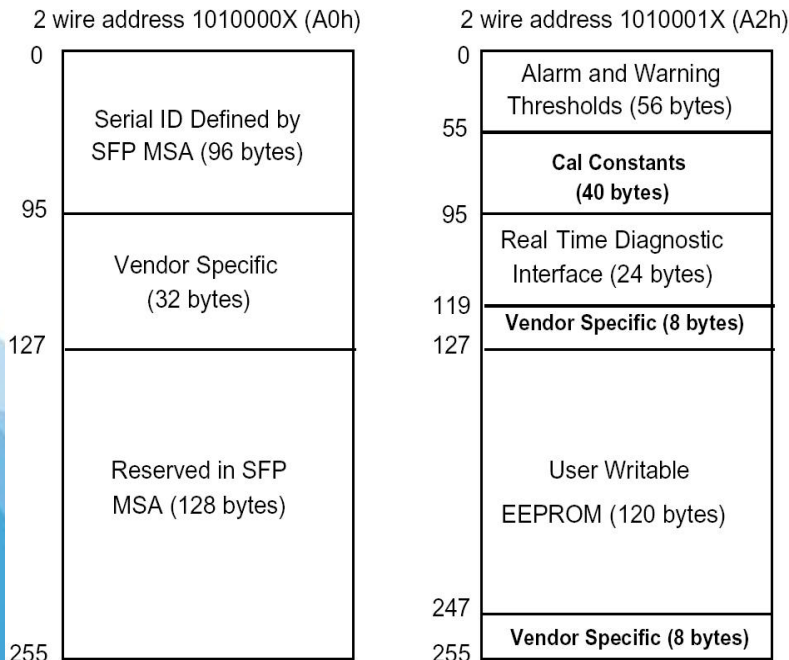

**Pin Definitions**

Pin Diagram

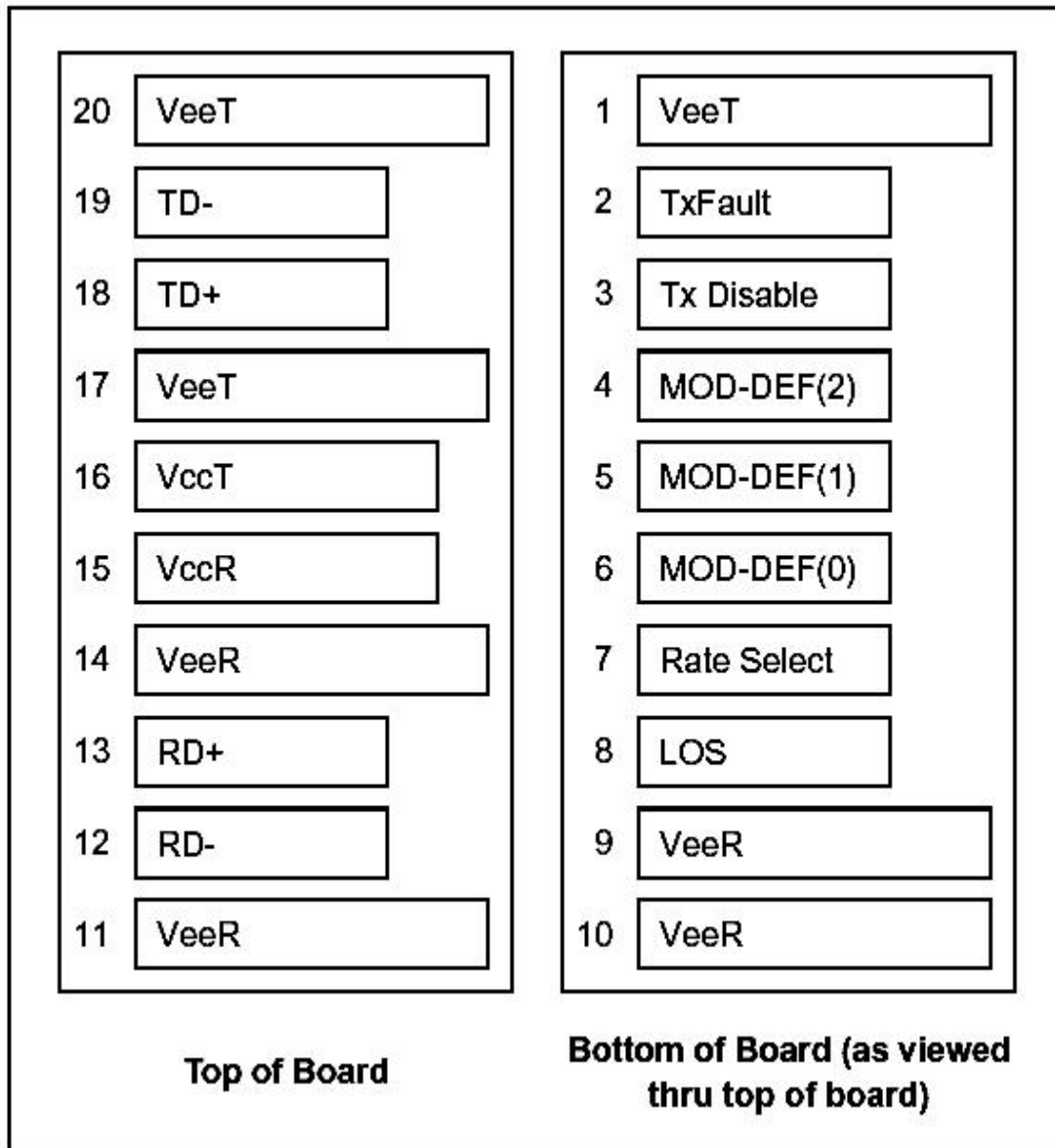

## Pin Descriptions

Pin	Signal Name	Description	Plug Seq.	Notes
1	V <sub>EET</sub>	Transmitter Ground	1	
2	TX FAULT	Transmitter Fault Indication	3	Note 1
3	TX DISABLE	Transmitter Disable	3	Note 2
4	MOD_DEF(2)	SDA Serial Data Signal	3	Note 3
5	MOD_DEF(1)	SCL Serial Clock Signal	3	Note 3
6	MOD_DEF(0)	TTL Low	3	Note 3
7	Rate Select	Not Connected	3	
8	LOS	Loss of Signal	3	Note 4
9	V <sub>EER</sub>	Receiver ground	1	
10	V <sub>EER</sub>	Receiver ground	1	
11	V <sub>EER</sub>	Receiver ground	1	
12	RD-	Inv. Received Data Out	3	Note 5
13	RD+	Received Data Out	3	Note 5
14	V <sub>EER</sub>	Receiver ground	1	
15	V <sub>CCR</sub>	Receiver Power Supply	2	
16	V <sub>CCT</sub>	Transmitter Power Supply	2	
17	V <sub>EET</sub>	Transmitter Ground	1	
18	TD+	Transmit Data In	3	Note 6
19	TD-	Inv. Transmit Data In	3	Note 6
20	V <sub>EET</sub>	Transmitter Ground	1	

### Notes:

Plug Seq.: Pin engagement sequence during hot plugging.

- TX Fault is an open collector output, which should be pulled up with a 4.7k~10kΩ resistor on the host board to a voltage between 2.0V and V<sub>cc</sub>+0.3V. Logic 0 indicates normal operation; Logic 1 indicates a laser fault of some kind. In the low state, the output will be pulled to less than 0.8V.
- TX Disable is an input that is used to shut down the transmitter optical output. It is pulled up within the module with a 4.7k~10kΩ resistor. Its states are:
 

Low (0 to 0.8V):	Transmitter on
(>0.8V, < 2.0V):	Undefined
High (2.0 to 3.465V):	Transmitter Disabled
Open:	Transmitter Disabled
- Mod-Def 0,1,2. These are the module definition pins. They should be pulled up with a 4.7k~10kΩ resistor on the host board. The pull-up voltage shall be V<sub>ccT</sub> or V<sub>ccR</sub>.  
 Mod-Def 0 is grounded by the module to indicate that the module is present  
 Mod-Def 1 is the clock line of two wire serial interface for serial ID  
 Mod-Def 2 is the data line of two wire serial interface for serial ID
- LOS is an open collector output, which should be pulled up with a 4.7k~10kΩ resistor. Pull up voltage between 2.0V and V<sub>cc</sub>+0.3V. Logic 1 indicates loss of signal; Logic 0 indicates normal operation. In the low state, the output will be pulled to less than 0.8V.
- RD-/+ : These are the differential receiver outputs. They are internally AC-coupled 100 differential lines which should be terminated with 100Ω (differential) at the user SERDES.
- TD-/+ : These are the differential transmitter inputs. They are internally AC-coupled, differential lines with 100Ω differential termination inside the module.

Recommended Interface Circuit

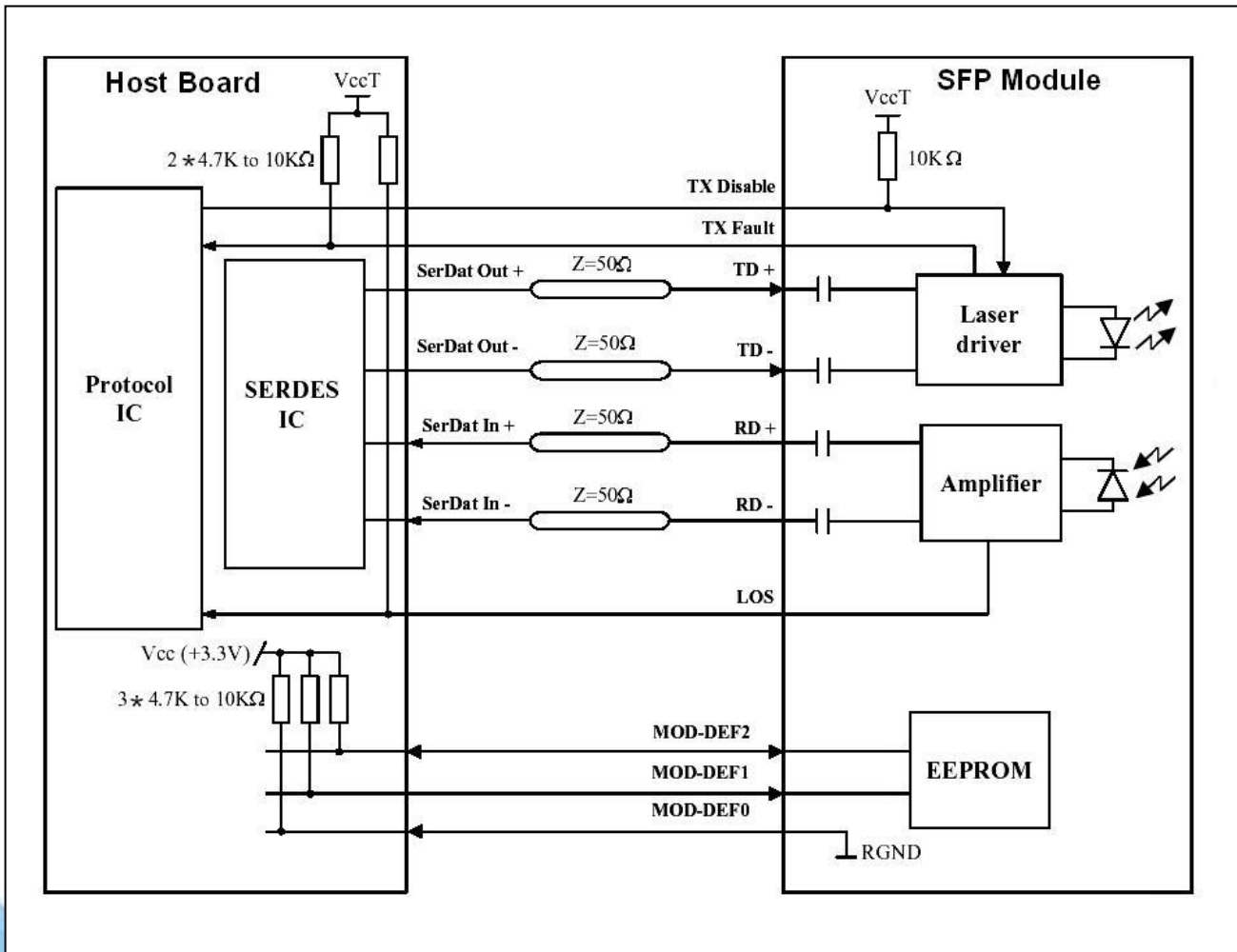

## Regulatory Compliance

COPTOLINK SFP transceiver is designed to be Class I Laser safety compliant and is certified per the following standards

Feature	Agency	Standard	Certificate / Comments
Laser Safety	FDA	CDRH 21 CFR 1040 and Laser Notice No. 50	1120295-000
Product Safety	BST	EN 60825-1: 2007 EN 60825-2: 2004 EN 60950-1: 2006	BT0905142001
Environmental protection	SGS	RoHS Directive 2002/95/EC	GZ0902007478/CHEM
EMC	CCIC	EN 55022: 2006+A1: 2007 EN 55024: 1998+A1: 2001+A2: 2003	CTE09020023

## Ordering information

Part Number	Product Description
COL-SFP-FE-EX	1310nm, 155Mbps SFP, 40km, 0°C ~ +70°C, With Digital Diagnostic Monitoring
COL-SFP-FE-EX-T	1310nm, 155Mbps SFP, 40km, -40°C ~ +85°C, With Digital Diagnostic Monitoring

## References

1. Small Form Factor Pluggable (SFP) Transceiver Multi-Source Agreement (MSA), September 2000.
2. Telcordia GR-253-CORE and ITU-T G.957 Specifications.

## Important Notice

Performance figures, data and any illustrative material provided in this data sheet are typical and must be specifically confirmed in writing by COPTOLINK before they become applicable to any particular order or contract. In accordance with the COPTOLINK policy of continuous improvement specifications may change without notice.

The publication of information in this data sheet does not imply freedom from patent or other protective rights of COPTOLINK or others. Further details are available from any COPTOLINK sales representative.

sales@coptolink.com  
www.coptolink.com